



EMERALD LAKES HOMEOWNERS' ASSOCIATION

3593 Medina Road, #182 • Medina, Ohio 44256



2024 DUES

Have you paid your dues?

Reminder that dues were due 1/31/2024. ***If your payment is not made by 4/30/24 a lien will be placed on your property and you will be responsible for paying your 2024 dues, the late fee, AND attorney's fees.*** Please mail your payments to: 3593 Medina Road, #182, Medina, Ohio 44256

SPRING CLEANING!

As you're thinking about spring cleaning this year are you also thinking about your property maintenance? We should take pride in our neighborhood and this starts with taking pride in our own homes. ***You are responsible for the upkeep of your landscaping, mailbox, and house.***

MAILBOX REQUIREMENTS

Friendly reminder that you have until August 31, 2024 to have your mailbox up to code. The flyer that indicates what is required is located [here](#). Questions, comments, or concerns should be directed to board@emerald lakes.org.

SAVE THE DATE: ANNUAL SPRING CLEAN UP

April 27, 2024 @ 9:00 AM

Meet us at 5785 Emerald Lakes Drive!

SAVE THE DATE: ANNUAL MAY GARAGE SALE

May 9-May 11, 2024 - 9 AM – 3 PM

Our neighborhood garage sale will take place again this year. We are advertising the event in Mimi's, Medina Gazette and the Plain Dealer.



LAKES AND TRAILS UPDATE

HELP US PROTECT OUR LAKES AND PONDS TO REDUCE ALGAE GROWTH:

- When mowing, all grass clippings will be aimed away from the lake and pond shorelines to prevent clippings from going into the water.
- When fertilizing, prevent the drainage into the lakes and ponds by:
 - avoiding the use of phosphorus-based fertilizers
 - care will be taken to not fertilize within 15 feet of the shoreline.
- Do not blow leaves or other yard waste into the lakes and ponds.
- If you are contracting with lawn and landscaping services, please share this information with your service provider.
- This information will also be a requirement of all companies providing services to any Emerald Lakes HOA lawn, trails, and gardens.

FISH STOCKING IN THE 3 MAIN LAKES

- Last October the three main lakes, 1) the lake on Lake Ridge, 2) the lake shared by Emerald Lakes and Champagne Shores and the lake on the bend of Emerald Lakes were all stocked with fish.
- The largemouth bass will be spawning this year. Please enjoy looking at the babies and be sure to ***immediately put all fish caught back into the lake.*** We want that population to grow.
- A new species was added to the population, steel carp grass ((triploid white amur), which are all male and sterile. They are herbivores, eat many of the invasive plants in our lakes and live for 5-10 years.
- We did not add blue gill as that population seemed quite healthy during our assessment last year.
- Both fish species meet the Ohio Department of Natural Resources requirements.

FALLEN TREES AND DEBRIS ON THE TRAILS

- Spring is finally here, and the trails will be enjoyed by many. If you see a fallen tree or other debris on a trail, please take a picture and email the board with a description of the location so we can find it easily.
Board@emeraldakes.org

FRIENDLY REMINDERS:

- Your grass clippings do NOT belong in the lake or street!
- Pick up after your dog!
- Be respectful to the people working in the development! We hire people to maintain our lakes, trails, and common areas and we should treat them with respect.
- Our lakes are catch and release ONLY.

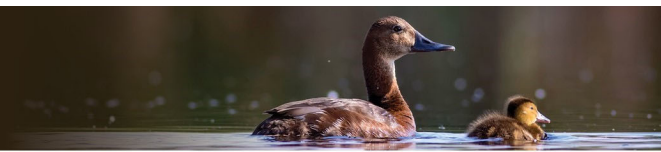

ARCHITECTURAL REVIEW

Are you planning on making home improvements this summer? Remember to check to see if you need to file an Architectural Review Form before you start! The form can be found [here](#).

DO YOU HAVE A NEW NEIGHBOR?

Let them know they can send their contact information to board@emeraldlakes.org to be added to our Newsletter!

Emerald Lakes Home Owners Association – “Mailbox By-Laws”

The ELHOA by-laws require homeowners to follow and abide by the rules set forth within Emerald Lakes HOA Covenants, Restrictions and By-Laws which can be viewed on our HOA website. Per the HOA By-Laws – “All mailboxes must be in a size, style, and color approved by the Homeowners’ Association and be maintained in good condition.”

<http://emeraldlakes.org/index.html>

These HOA covenants were established to maintain a consistent and pleasing appearance of our neighborhood which ultimately enhances our home values and aligns with the governance of Montville Township Planning & Zoning Resolutions.

<https://montvilletwp.net/>

With Spring quickly approaching, we are respectfully requesting each Homeowner review and update their mailbox per the HOA by-law design by **August 31, 2024**. Failure to comply may result in the HOA taking further action.

Website Mailbox Design Details (Instructions / Material List / Pictures / Diagrams)

<http://emeraldlakes.org/MAILBOX-1.html>

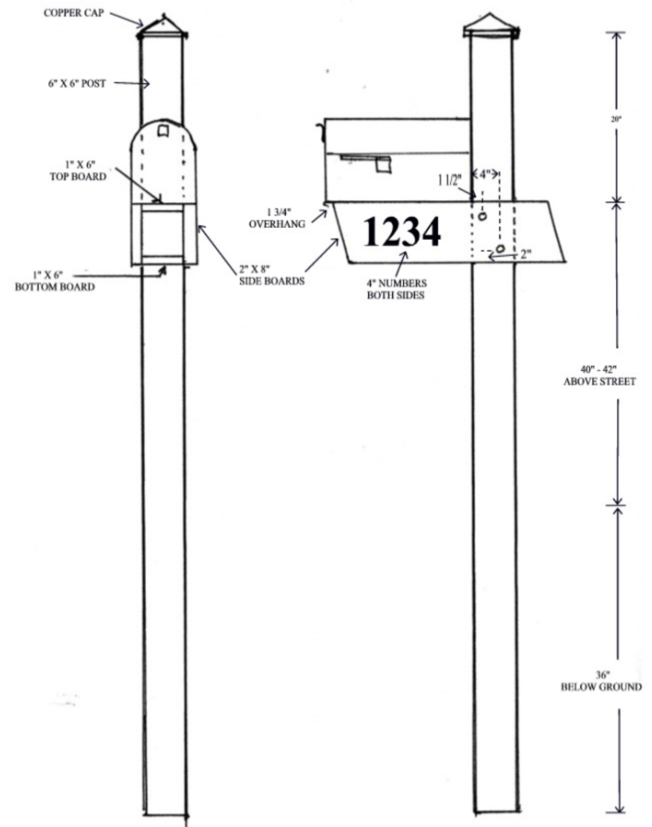

The Emerald Green Mailbox can be ordered from:

- 1) Ace Hardware / Buehlers - 330-725-5000
- 2) Item #5266226; Manufacturer #E1600GAM (Gibraltar Mailboxes – Elite)
- 3) <https://www.acehardware.com/departments/hardware/mailboxes-and-posts/mailboxes/5266226>

Approved Mailbox Posts

- 1) Option #1 (Homeowner build and install)
 - a. Per design plan located on ELHOA website
 - b. Finish
 - i. Paint - Ace Hardware (Benjamin Moore Revere Pewter #HC-172) or
 - ii. Stain – Behr solid color house & fence stain #507 Tucson White #082474337011
- 2) Option #2 (Purchase from A Sign Above) – see attached flyer below
 - a. Jerry Keller 216-337-2201
 - b. jerryasignabove@yahoo.com

Copper Post Cap

- a. Deckorators 6-in x 6-in high point copper plastic pine deck post cap
- b. Lowe’s Item #65588 / Model #72224 (located in the decking section)
- c. <https://www.lowes.com/pd/Deckorators-Fits-Common-Post-Measurement-6-in-x-6-in-Actual-8-in-x-8-in-x-3-25-in-High-Point-Copper-Unlit-Plastic-Pine-Deck-Post-Cap/3185309>

Spring Is Here

Improve your curb appeal with a new mailbox!

\$485*

Includes Removal & Installation

(*\$425 For Just Mailbox Delivered)

HOA Approved

Ready In 2-3 Weeks!

Contact **Jerry Keller**
for more information.
216-337-2201
jerryasignabove@yahoo.com

asa
a sign above
8982 Dutton Drive
Twinsburg, Ohio 44087
Phone: (330) 425-7832

Find Us On The Web At:
a-sign-above.com

Like Us On Facebook

Actual Mailbox

**EMERALD LAKES HOMEOWNERS' ASSOCIATION
ARCHITECTURAL REVIEW APPLICATION**

WHEN DO YOU FILE A DESIGN / ALTERATION REVIEW APPLICATION?

All homeowners' in Emerald Lakes must submit an application form for any addition or change to the exterior of their building or external structures (deck/patio, fences, sheds, pools, play equipment, etc). In addition, pursuant the Declaration's Lake Lot Restrictions, Lake Lot owners' must obtain prior approval for changes or landscaping of the backyards. If in doubt about your particular project, contact Brian Baddorf, Chairman of the Architectural Review Committee. Phone: 440-804-4378

WHAT IS THE OBJECT OF THIS FORM?

The object of requiring a homeowner to file an improvement application with the Board is two-fold:

1. To ensure that your planned improvement conforms to the Association's Declaration, enhances the beauty of the Community, maintains the architectural harmony of the Community and in no way inconveniences your fellow homeowners.
2. To enable the Association to determine what information and assistance it can give in order to expedite completion of your planned improvement.

Name: _____

Address: _____

Date: _____ Phone Number: _____ Owner: ____ Renter ____

Type & Nature of Requested Improvement: _____

Color: _____ Dimensions: _____ Location: _____

A **SCALE** drawing of all improvements must be submitted and attached to the application to show the exact location and dimensions.

I understand the rules concerning the proposed improvement. This improvement in no way encroaches on a neighbor's property or common ground. I agree to abide by the rules established by the Association and will be solely liable for any upkeep required by the addition of this improvement. I further agree to obtain all licenses and/or building permits and to meet all legal requirements for building codes.

Date: _____ Signature: _____

------(FOR ASSOCIATION USE ONLY)-----

Date Received: _____ Received by: _____ Date

Approved: _____ Date Disapproved: _____

Letter Sent: _____ Special Details or provisions for approval:

Abutters advised (if necessary) YES NO

Return this completed form and all attachments to:
Greg Terrell 3524 Emerald Lakes Drive
Chairman of the Architectural Review Committee.

Revised: 2/15/2024